



TECHNOLOGY
PIONEER
IN CLEAN ENERGY



EP2000 & B700 Whole-House ESS

Secure Home Power, Save on Bills

10.5 kW-20 kW | 14.7 kWh-51.6 kWh | Three-Phase | On-Grid / Off-Grid



EP2000 Whole-House ESS

Accelerate home energy transition with ease.

EP2000 and B700 energy storage system is BLUETTI's latest powerhouse integrating a hybrid solar inverter with a high-capacity energy storage battery. This all-in-one solution is tailor-made for villas, large standalone houses, small businesses, farms, and other high-power-demand situations.

With an outstanding 20 kW AC output and a 30 kW PV input, the EP2000 ESS maximizes solar energy utilization, effortlessly powering whole-house appliances, including EV and heat pumps.

Enjoy unrivaled energy independence and significant savings on electricity bills with minimal upfront investment.

EP2000
Hybrid Inverter

HV800
Battery Controller

B700
Expansion Battery

B700
Expansion Battery



One Powers All

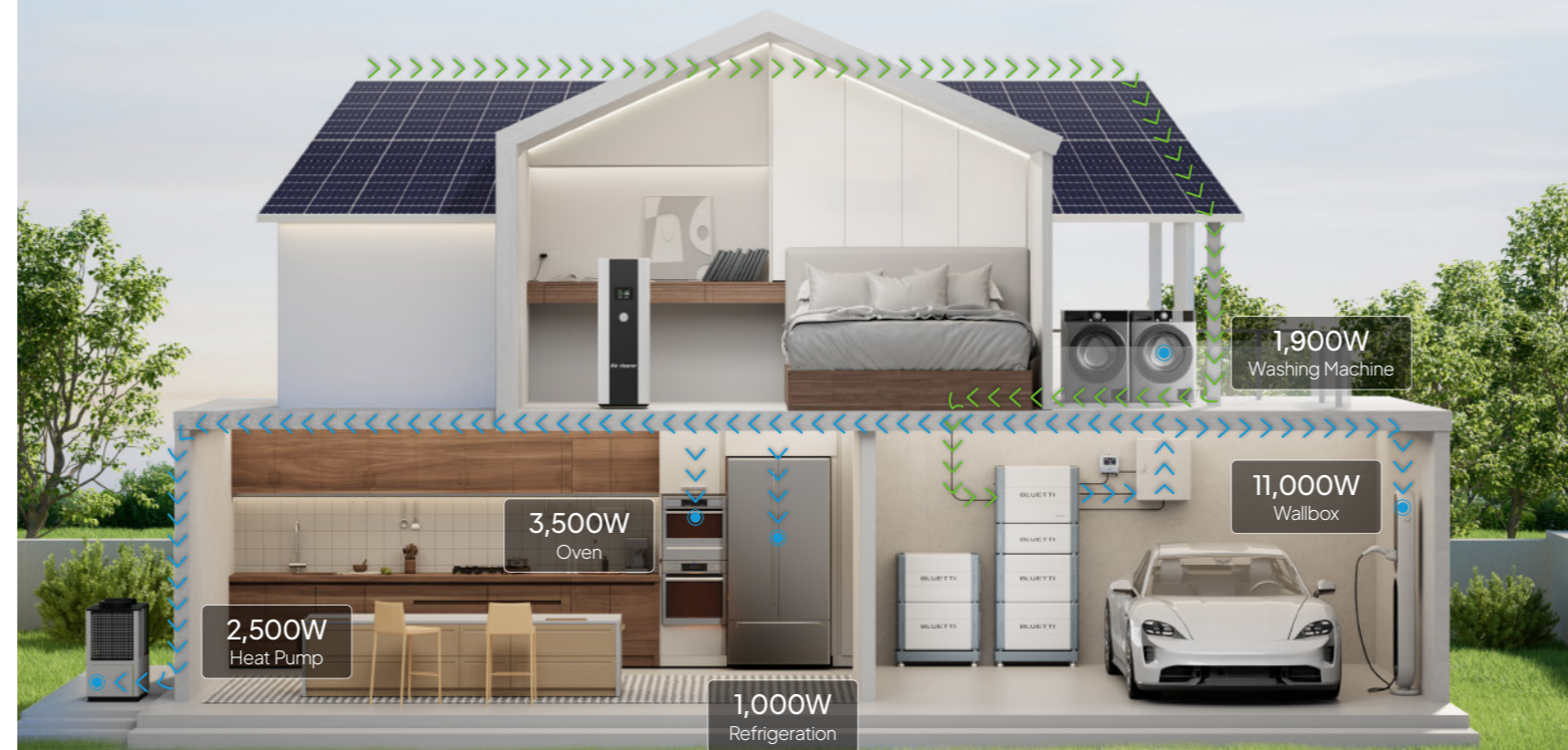

Why Choose BLUETTI EP2000 ESS

Higher ROI



- Achieve 100% energy self-sufficiency with up to 20 kW power output and 30 kW PV input. Invest one BLUETTI ESS, and get the same returns that require two units from other brands.
- Up to 97.6% Efficiency: The high voltage system ensures an impressive inverter efficiency, maximizing energy conversion and reducing waste.

More Powerful & Flexible Energy Solution



- Power whole house with 10.5 kW / 15.5 kW / 20 kW optional output power and 14.7 kWh-51.6 kWh expandable capacity.
- Parallel connection with up to 3 EP2000 units for max. 60 kW output and 154.8 kWh capacity. Customize based on residential or commercial needs without paying for unnecessary capacity.

Time-Saving & Hassle-Free



- All-in-One: Combines a hybrid solar inverter and energy storage system for seamless operation and stability.
- Modular: Easy to expand, transport, and install with a plug-and-play feature, enhancing installation efficiency by 50% compared to the previous generation.

Universal Compatibility



- Whether you have an existing solar rooftop or plan to install a new one, the EP2000 ESS offers excellent compatibility to integrate with any setup.

More Features



- 10-Year Warranty
- Safest LFP Batteries
- Elegant Appearance
- Smart App Control
- Seamless Backup
- IP65 Protection Rating
- Switch in 10ms

Power for Every Scenario

EP2000 Inverter + HV800 Battery Controller	B700	Rated Output Power / kW (on / off grid)	Rated Output (With PV input)	Capacity / kWh
1	2	10.5	20	14.7
	3	15.5	20	22.1
	4	20	20	29.49
	5			36.86
	6			44.2
7	51.6			
2*	4-14	40 Max.	40 Max.	103.2 Max.
3*	6-21	60 Max.	60 Max.	154.8 Max.

*The parallel connection is expected to be available in Q4 2024.



4 APP Working Modes Power Intelligence at Your Fingertips

Self-Consumption
Perfect for sunny areas with high electricity costs.

Backup
Providing uninterrupted power supply for areas with unreliable grids.

Time of Use
Great for stable grids with big price differences between peak and off-peak times.

Custom Mode
Get tailored solutions with the BLUETTI app.

How it Works

One EP2000 ESS for Whole-House Usage

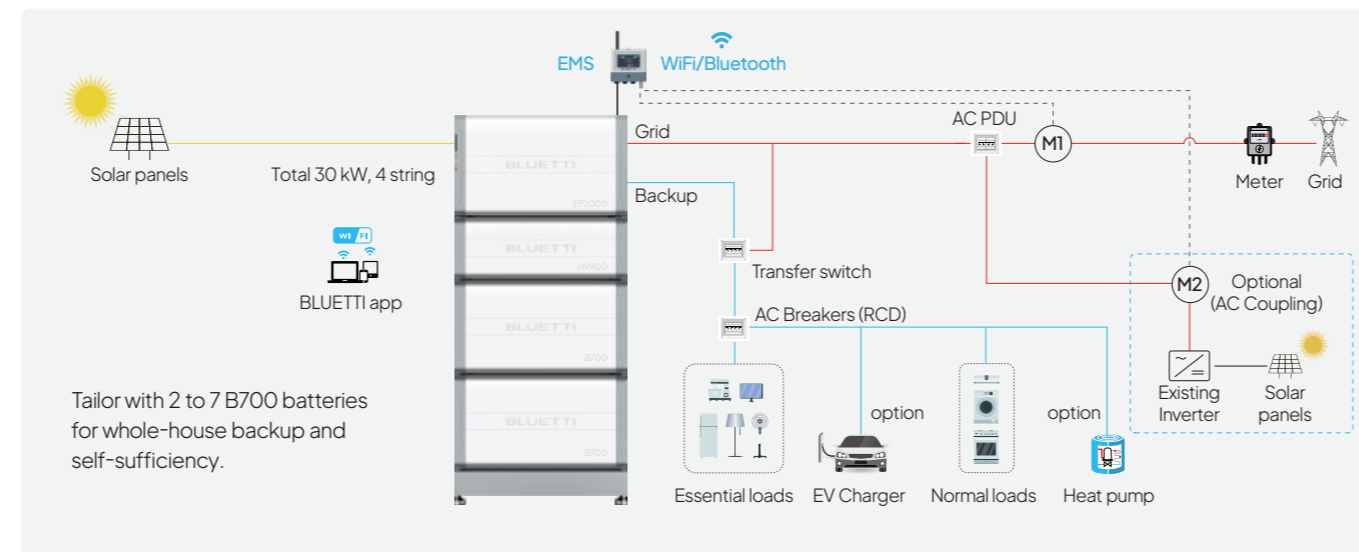

Parallel Connection for Small Businesses

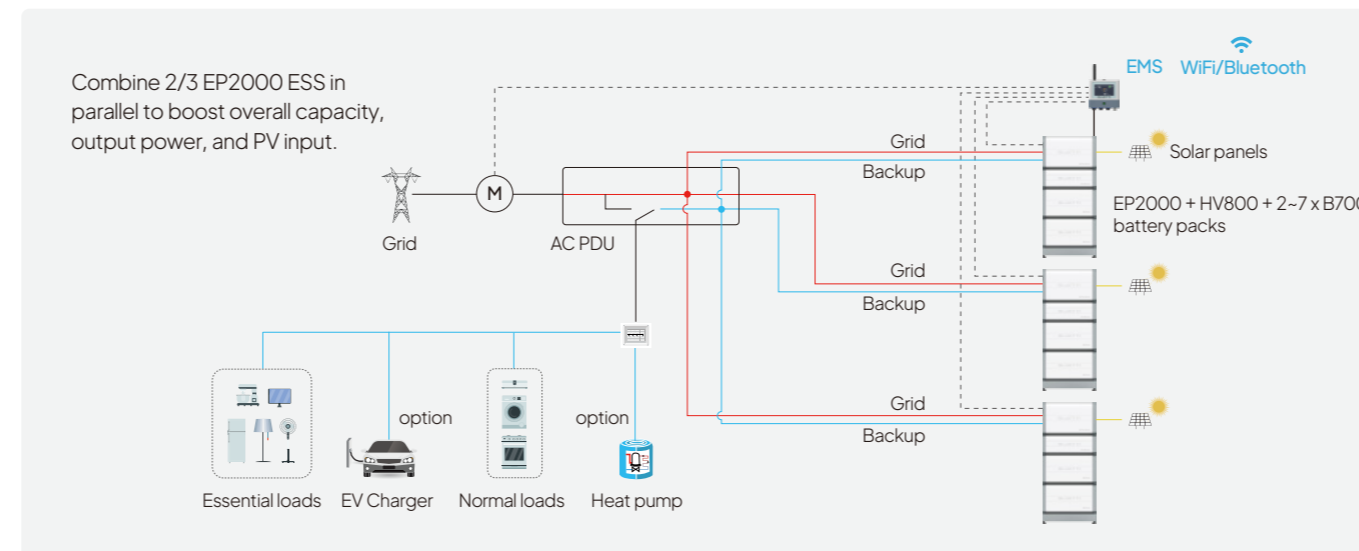

1xEP2000 + HV800 + 2x B700

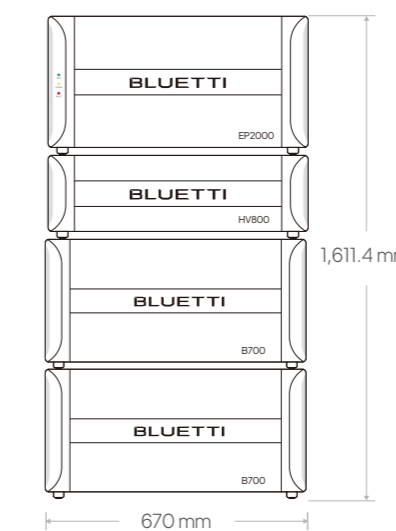

1xEP2000 + HV800 + 4x B700

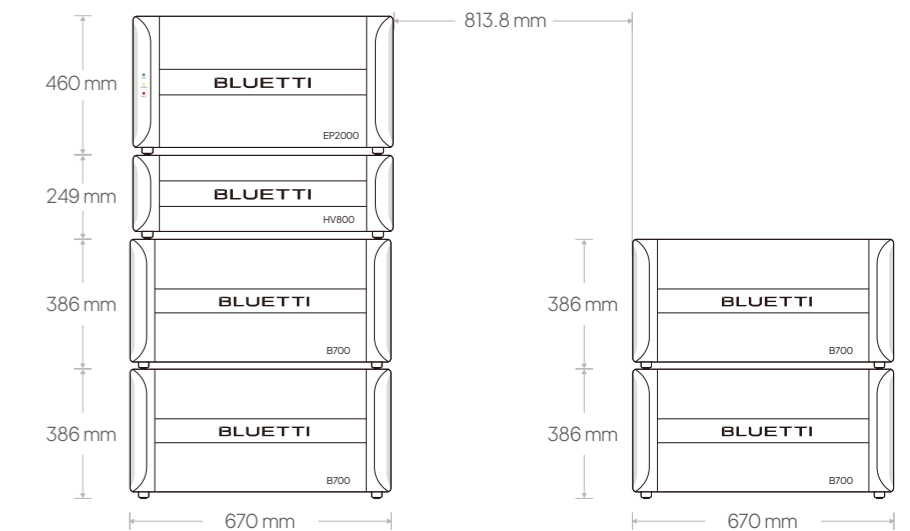

EP2000 Hybrid Inverter

General		Warranty	
Operating Temperature	-20°C to 60°C	Warranty	10 Years
Noise	≤50dB	Dimensions (L x W x H)	670 mm x 280 mm x 460 mm
Net Weight	60 kg	Input Frequency	50 Hz
Cooling	Forced Air Cooling	Switch Over Time to Backup Power	<10 ms
Connectivity	USB / Wi-Fi / Bluetooth	Phase	3L / N / PE
Protection Rating	IP65	AC OUTPUT (BACKUP)	
Input Apparent Power (Bypass + Charging)	40 kVA Max.	Rated Power	10.5 kW with 2 B700 15.5 kW with 3 B700 20 kW with 4-7 B700
PV INPUT		Rated Output (With PV input)	20kW
Power	30 kW Max.	Rated Voltage	230 / 400 VAC
MPPT Voltage Range / Rated Voltage	160 V-850 V / 500 V	Frequency	50 Hz
MPPT Channel / Strings per MPPT	2 / 2	Compliances	
Single MPPT Input Current	30 A	Grid Connections**	Germany: VDE-AR-N 4105:2018, DIN VDE V0124-100:2020, Austria: TOR Erzeuger Type A version 1.2, 18 April 2022 Australia: AS / NZS 4777.2:2020 Amd 1:2021
Single MPPT Short Circuit Current	40 A	Safety	IEC 62109-1, IEC 62109-2, EN 62109-1, EN 62109-2
Initial input voltage	180V	RoHS	2011 / 65/EU and (EU) 2015/863
Max. input voltage	1,000V	Emissions	EN/IEC 61000-6-3, EN/IEC 61000-6-1
Compliances		HV800 Voltage Controller	
Safety		General	
IEC 62109-1, IEC 62109-2, EN 62109-1, EN 62109-2		Expandability	
RoHS		2-7 B700 Batteries	
Emissions		Voltage Range	
EN/IEC 61000-6-3, EN/IEC 61000-6-1		130 V-800 V	
EN/IEC 61000-6-3, EN/IEC 61000-6-1		Max. Current	
2011/65/EU and (EU) 2015/863		70 A Max.	
2011/65/EU and (EU) 2015/863		Net Weight	
2011/65/EU and (EU) 2015/863		19 kg	
2011/65/EU and (EU) 2015/863		Compliances	
2011/65/EU and (EU) 2015/863		Safety	
2011/65/EU and (EU) 2015/863		IEC 62619, EN 62619, VDE-AR-E 2510-50, UN38.3	
2011/65/EU and (EU) 2015/863		B700 Battery	
2011/65/EU and (EU) 2015/863		General	
2011/65/EU and (EU) 2015/863		Battery Chemistry	
2011/65/EU and (EU) 2015/863		LiFePO4	
2011/65/EU and (EU) 2015/863		Capacity	
2011/65/EU and (EU) 2015/863		7,372.8Wh	
2011/65/EU and (EU) 2015/863		Protection Grade	
2011/65/EU and (EU) 2015/863		IP65	
2011/65/EU and (EU) 2015/863		Net Weight	
2011/65/EU and (EU) 2015/863		72kg	
2011/65/EU and (EU) 2015/863		Dimensions	
2011/65/EU and (EU) 2015/863		670 mmx280 mmx386 mm	

HV800 Voltage Controller	
Dimensions (L x W x H)	670 mm x 280 mm x 249 mm
Noise	<25dB
Warranty	10 Years
Compliances	
Emissions	EN/IEC 61000-6-3, EN/IEC 61000-6-1
RoHS	2011/65/EU and (EU) 2015/863

B700 Battery	
General	
Battery Chemistry	LiFePO4
Capacity	7,372.8Wh
Protection Grade	IP65
Net Weight	72kg
Dimensions	670 mmx280 mmx386 mm

** Specifications subject to change without further notice.



Contact Us